

Body type **L0 - 2 way**

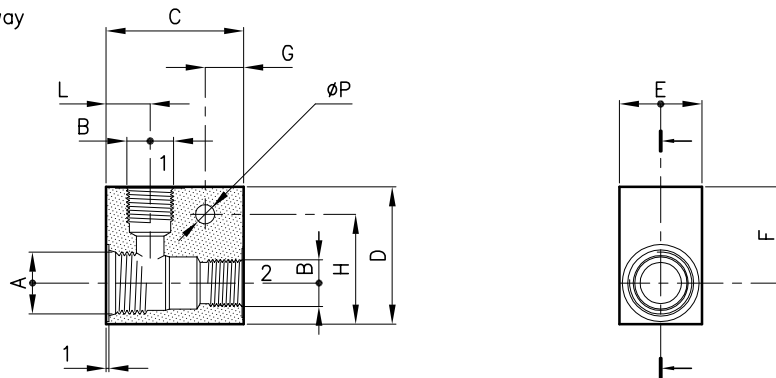

Series	Aluminium	Steel	A	B	C	D	E	F	G	H	L	M	N	P
20	20-LO-B05	..-B05/FE	S 20/2	G 1/4 (B05)	50	45	30	30	14	35	14			7
	20-LO-B06	..-B06/FE	M 18x1.5	G 3/8 (B06)	50	45	30	30	14	35	14			7
28	28-LO-B05	..-B05/FE	S 28/3	G 1/4 (B05)	50	45	30	30	14	35	16			7
	28-LO-B06	..-B06/FE	3/4-16 UNF	G 3/8 (B06)	50	45	30	30	14	35	16			7
30	30-LO-B06	..-B06/FE	S 30/2	G 3/8 (B06)	50	50	30	35	14	40	16			7
	30-LO-B08	..-B08/FE	M 22x1.5	G 1/2 (B08)	50	50	30	35	14	40	16			7
50	50-LO-B08	..-B08/FE	S 50/2	G 1/2 (B08)	70	70	45	45	14	55	22			9
	50-LO-B12	..-B12/FE	M 33x2	G 3/4 (B12)	70	70	45	45	14	55	22			9
70	70-LO-B16	..-B16/FE	S 70/2	G 1 (B16)	90	90	60	60	30	70	27			10.5
	70-LO-B20	..-B20/FE	M 42x2	G 1.1/4 (B20)	90	90	60	60	30	70	27			10.5

Body type **C3 - 3 way**

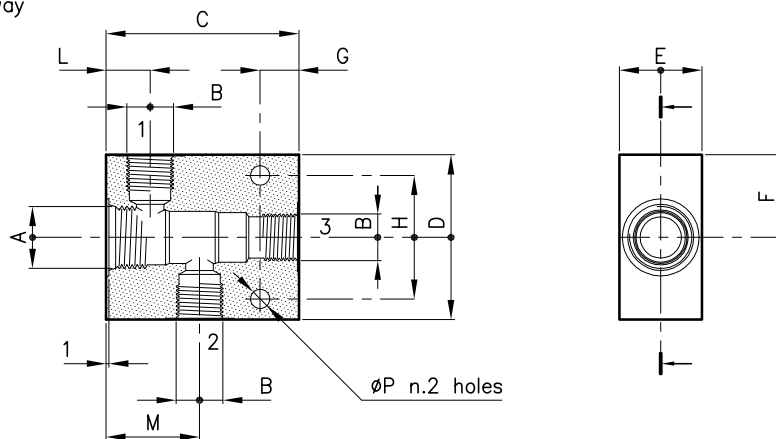

Series	Aluminium	Steel	A	B	C	D	E	F	G	H	L	M	N	P
20	20-C3-B05	..-B05/FE	S 20/3	G 1/4 (B05)	60	60	30	30	14	35	14	29		7
	20-C3-B06	..-B06/FE	M 18x1.5	G 3/8 (B06)	60	60	30	30	14	35	14	29		7
28	28-C3-B05	..-B05/FE	S 28/3	G 1/4 (B05)	60	60	30	30	14	35	16	30		7
	28-C3-B06	..-B06/FE	3/4-16 UNF	G 3/8 (B06)	60	60	30	30	14	35	16	30		7
30	30-C3-B06	..-B06/FE	S 30/3	G 3/8 (B06)	70	60	30	30	14	45	16	34		7
	30-C3-B08	..-B08/FE	M 22x1.5	G 1/2 (B08)	75	70	35	35	14	45	16	34		7
50	50-C3-B08	..-B08/FE	S 50/3	G 1/2 (B08)	90	90	45	45	14	60	22	47		9
	50-C3-B12	..-B12/FE	M 33x2	G 3/4 (B12)	90	90	45	45	14	60	22	47		9
70	70-C3-B16	..-B16/FE	S 70/3	G 1 (B16)	120	120	60	60	25	90	27	58		10.5
	70-C3-B20	..-B20/FE	M 42x2	G 1.1/4 (B20)	120	120	60	60	25	90	27	58		10.5