

**Technical features**

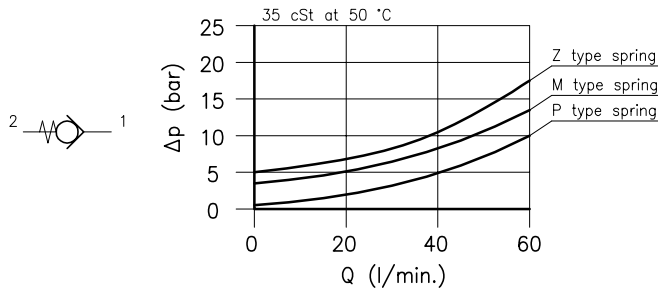

Cavity	(For dimensions see catalogue 17.000)	S 30/2
Nominal flow	(l/min.)	60
Max. pressure	(bar)	420
Cracking pressure	(bar)	0.35-3.5-5
Fluid viscosity range	(cSt)	2.8 - 380
Fluid temperature range	(°C)	-20 +80
Mass	(kg)	0.100
Hydraulic fluid; mineral oil HM and HV		ISO 6074
Recommended filtration; 19/15 ISO 4466 (25 μ absolutes)		
Standard seals in Polyurethane and Buna N		

**Dimensions**

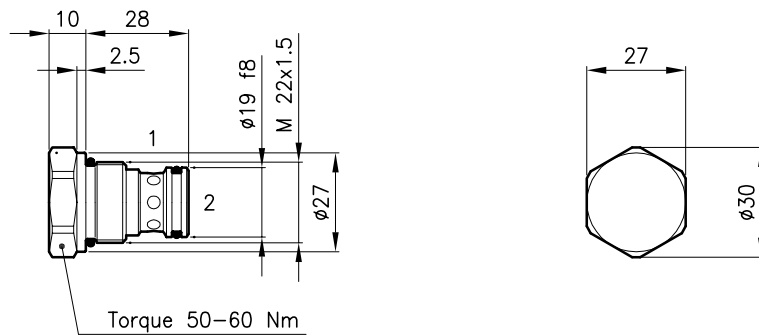

**Ordering informations**

**EAC 30/P**

**EAC 30** = Valve type



Standard springs

**P** = 0.35 bar

**M** = 3.5 bar

**Z** = 5 bar

Codes:

EAC 30/P 32 011 176

EAC 30/M 32 011 177

EAC 30/Z 32 011 178

External seals kit 90 620 103

EAC 30 valves can be assembled on standard bodies 30-LO series; for dimensions see catalogue 16.010