

Technical features

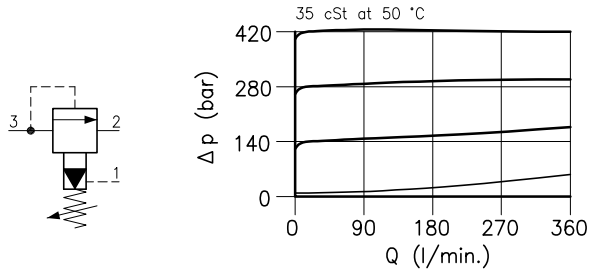

Cavity	(For dimensions see catalogue 17.000)	S 70/3
Max. flow	(l/min.)	320
Max. inlet pressure	(bar)	420
Max. pressure on line 2	(bar)	350
Max. drain on line 1	(l/min.)	1.2
Fluid viscosity range	(cSt)	2.8 – 380
Fluid temperature range	(°C)	-20 +80
Mass	(kg)	0.700
Standard setting obtained with 10 l/min.		
Hydraulic fluid; mineral oil HM and HV		ISO 6074
Recommended filtration; 19/15 ISO 4466 (25 μ absolutes)		
Standard seals in Polyurethane and Buna N		

Dimensions

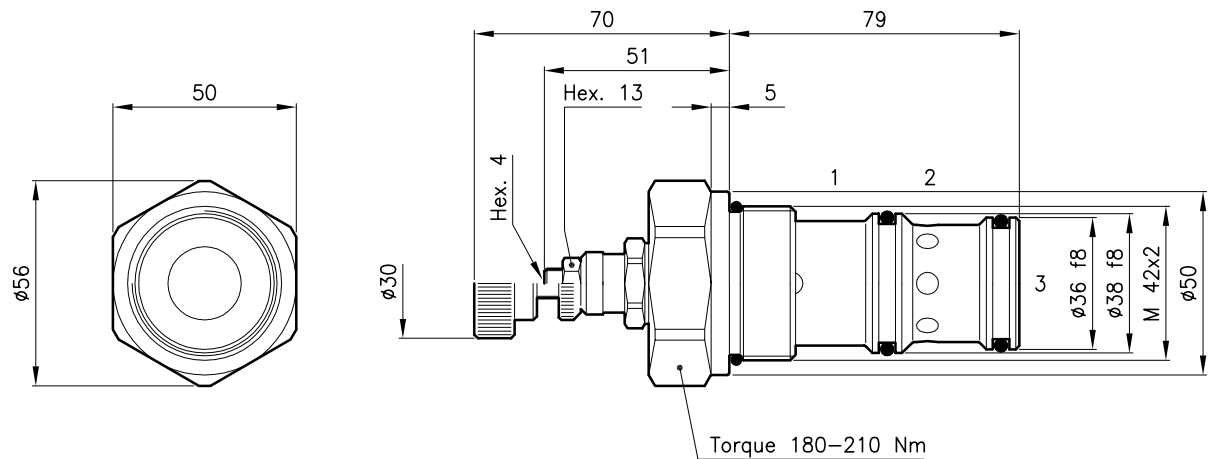

Ordering informations

LPY 70/D-N

LPY 70 = Valve type

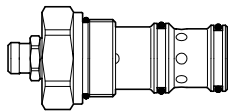

Standard springs

Type	Setting range	Factory set
D	= 10 – 210 bar	140 bar
Q	= 105 – 420 bar	315 bar

Adjustment type

- N** = Standard adjustment
- V** = Handknob adjustment

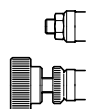

Codes:

LPY 70/D-N	71 011 114
LPY 70/Q-N	71 011 115
LPY 70/D-V	71 011 116
LPY 70/Q-V	71 011 117
External seals kit	90 620 120

LPY 70 valves can be assembled on standard bodies 70-C3 series; for dimensions see catalogue 16.010