

**Technical features**

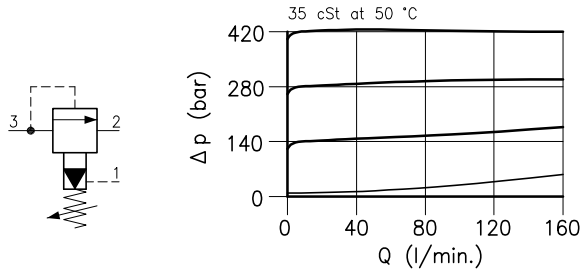

Cavity	(For dimensions see catalogue 17.000)	S 50/3
Max. flow	(l/min.)	160
Max. inlet pressure	(bar)	420
Max. pressure on line 2	(bar)	420
Max. drain on line 1	(l/min.)	1.2
Fluid viscosity range	(cSt)	2.8 - 380
Fluid temperature range	(°C)	-20 +80
Mass	(kg)	0.400
Standard setting obtained with 10 l/min.		
Hydraulic fluid; mineral oil HM and HV		ISO 6074
Recommended filtration; 19/15 ISO 4466 (25 μ absolutes)		
Standard seals in Polyurethane and Buna N		

**Dimensions**

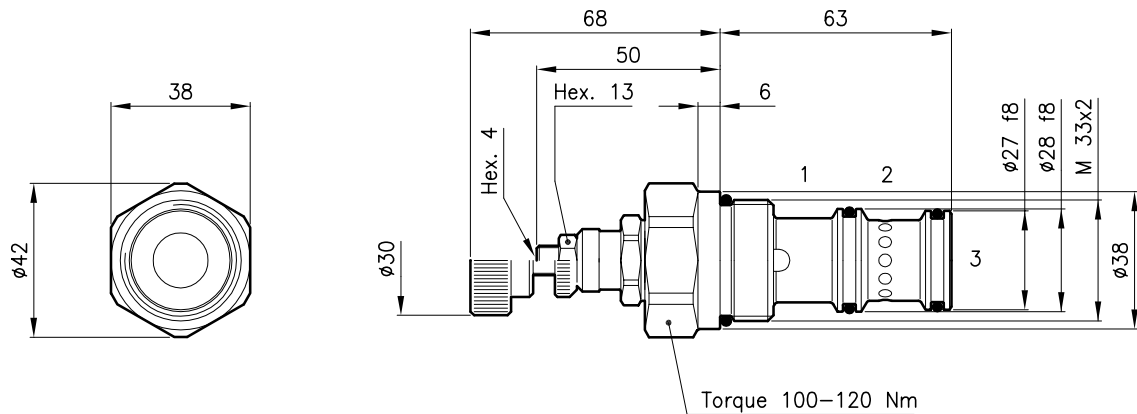

**Ordering informations**

**LPY 50/D-N**

LPY 50 = Valve type

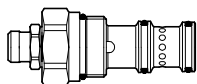

Standard springs

Type	Setting range	Factory set
<b>D</b>	= 10 - 210 bar	140 bar
<b>Q</b>	= 105 - 420 bar	315 bar

Adjustment type

- N** = Standard adjustment
- V** = Handknob adjustment

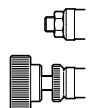

Codes:

LPY 50/D-N	51 011 115
LPY 50/Q-N	51 011 116
LPY 50/D-V	51 011 117
LPY 50/Q-V	51 011 118
External seals kit	90 620 107

LPY 50 valves can be assembled on standard bodies 50-C3 series; for dimensions see catalogue 16.010