

**Technical features**

LPQ 50 valves are used to unload a line under pressure or as sequence valve. At setting pressure achievement the valve opens itself allowing the free passage with a very low pressure drop.

The valve closes when pressure falls under a 7 bar value.

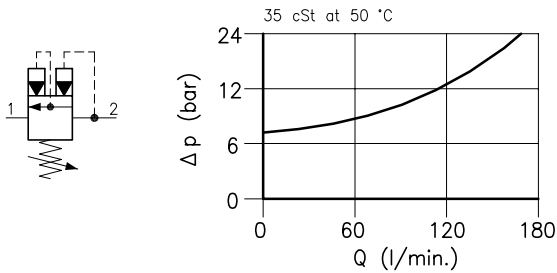

Cavity	(For dimensions see catalogue 17.000)	S 50/2
Max. flow	(l/min.)	160
Max. inlet pressure	(bar)	420
Max. pressure on line 1	(bar)	210
Fluid viscosity range	(cSt)	2.8 – 380
Fluid temperature range	(°C)	-20 +80
Max. reseal pressure	(bar)	7
Max. leakage	(cm <sup>3</sup> /min.)	25
Mass	(kg)	0.500
Cracking pressure 95% of setting value		
Cracking pressure defined with 1 l/min.		
Hydraulic fluid; mineral oil HM and HV ISO 6074		
Recommended filtration; 19/15 ISO 4466 (25 μ absolutes)		
Standard seals in Polyurethane and Buna N		

**Dimensions**

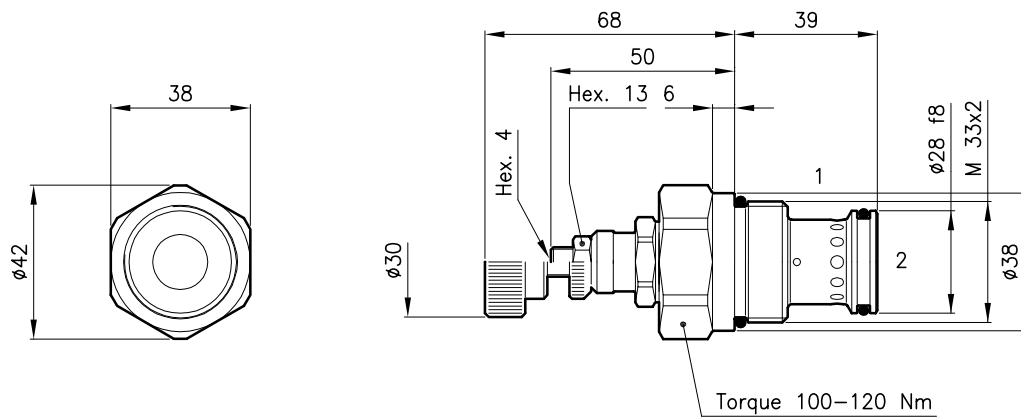

**Ordering informations**

**LPQ 50/D-N**

LPQ 50 = Valve type

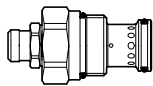

Standard springs

Type	Setting range	Factory set
<b>D</b>	= 14 – 210 bar	140 bar
<b>Q</b>	= 105 – 420 bar	315 bar

Adjustment type

**N** = Standard adjustment

**V** = Handknob adjustment

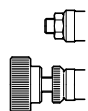

Codes:

LPQ 50/D-N	51 011 111
LPQ 50/Q-N	51 011 112
LPQ 50/D-V	51 011 113
LPQ 50/Q-V	51 011 114
External seals kit	90 620 106

LPQ 50 valves can be assembled on standard bodies 50-LO series; For dimensions see catalogue 16.010