

Technical features

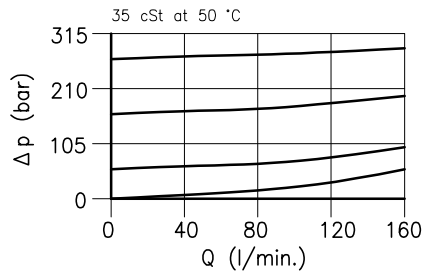

Cavity (For dimensions see catalogue 17.000)	S 50/2
Max. flow (l/min.)	160
Max. inlet pressure (bar)	350
Max. pressure on line 2 (bar)	350
Fluid viscosity range (cSt)	2.8 – 380
Fluid temperature range (°C)	-20 +80
Mass (kg)	0.910
Cracking pressure 95% of setting value	
Reseat pressure 75% of setting value	
Cracking pressure defined with 1 l/min.	
Standard setting obtained with 10 l/min.	
Hydraulic fluid; mineral oil HM and HV ISO 6074	
Recommended filtration; 19/15 ISO 4466 (25 μ absolutes)	
Standard seals in Polyurethane and Buna N	

Dimensions

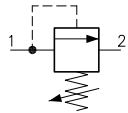
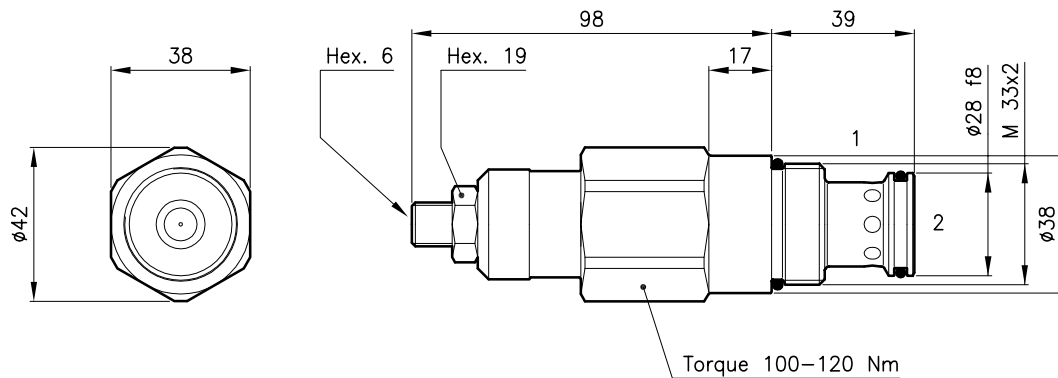

Ordering informations

LPB 50/D-N

LPB 50 = Valve type

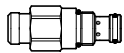

Standard springs

Type	Setting range	Factory set
U	= 10 – 105 bar	70 bar
D	= 70 – 210 bar	140 bar
T	= 140 – 350 bar	280 bar

Adjustment type

N = Standard adjustment



Codes:

LPB 50/U-N	51 011 100
LPB 50/D-N	51 011 101
LPB 50/T-N	51 011 102

External seals kit 90 620 106

LPB 50 valves can be assembled on standard bodies 50-LO series; for dimensions see catalogue 16.010