

Technical features

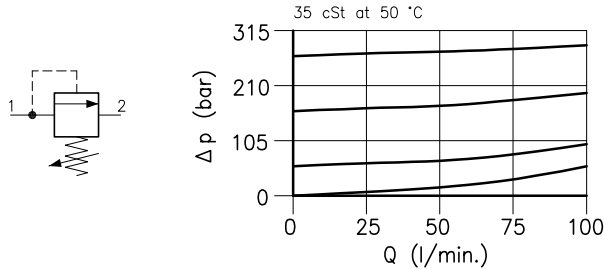

Cavity	(For dimensions see catalogue 17.000)	S 30/2
Max. flow	(l/min.)	90
Max. inlet pressure	(bar)	350
Max. pressure on line 2	(bar)	350
Fluid viscosity range	(cSt)	2.8 – 380
Fluid temperature range	(°C)	-20 +80
Mass	(kg)	0.270
Cracking pressure 95% of setting value		
Reseat pressure 75% of setting value		
Cracking pressure defined with 1 l/min.		
Standard setting obtained with 10 l/min.		
Hydraulic fluid; mineral oil HM and HV ISO 6074		
Recommended filtration; 19/15 ISO 4466 (25 μ absolutes)		
Standard seals in Polyurethane and Buna N		

Dimensions

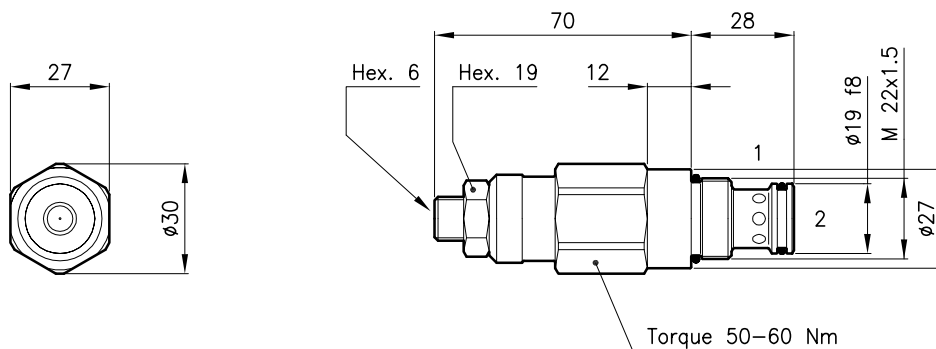

Ordering informations

LPB 30/D-N

LPB 30 = Valve type

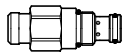

Standard springs

Type	Setting range	Factory set
U	= 10 – 105 bar	70 bar
D	= 70 – 210 bar	140 bar
T	= 140 – 350 bar	280 bar

Adjustment type

N = Standard adjustment



Codes:

LPB 30/U-N	31 011 104
LPB 30/D-N	31 011 105
LPB 30/T-N	31 011 106

External seals kit 90 620 103

LPB 30 valves can be assembled on standard bodies 30-LO series; for dimensions see catalogue 16.010