

Technical features

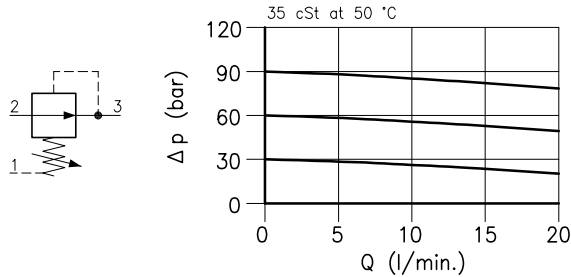

Cavity (For dimensions see catalogue 17.000)	S 20/3
Max. flow (l/min.)	20
Max. inlet pressure (bar)	420
Pressure setting range (bar)	5 - 90
Max. drain (l/min.)	0.05
Fluid viscosity range (cSt)	2.8 - 380
Fluid temperature range (°C)	-20 +80
Mass (kg)	0.160
Standard setting obtained with 1 l/min.	
Hydraulic fluid; mineral oil HM and HV	ISO 6074
Recommended filtration; 19/15 ISO 4466 (25 μ absolutes)	
Standard seals in Polyurethane and Buna N	

Dimensions

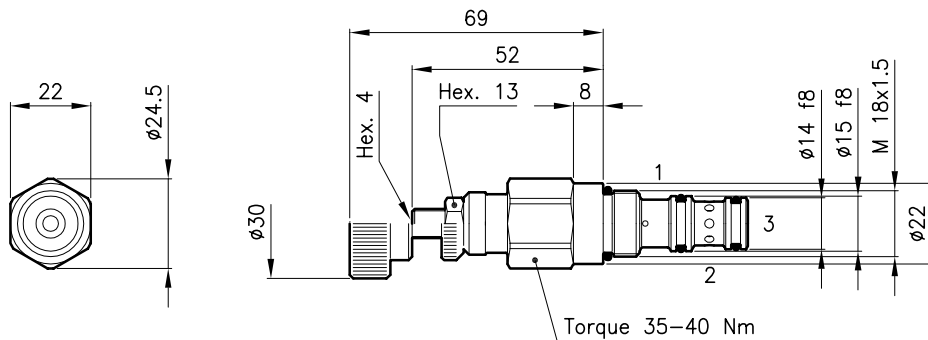

Ordering informations

RPA 20/D-N

RPA 20 = Valve type

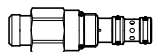

Standard springs

Type	Setting range	Factory set
U	5 - 30 bar	20 bar
D	14 - 60 bar	40 bar
T	35 - 90 bar	70 bar

Adjustment type

N = Standard adjustment

V = Handknob adjustment

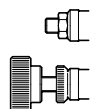

Codes:

RPA 20/U-N	21 011 113
RPA 20/D-N	21 011 114
RPA 20/T-N	21 011 115
RPA 20/U-V	21 011 116
RPA 20/D-V	21 011 117
RPA 20/T-V	21 011 118

External seals kit 90 620 101

RPA 20 valves can be assembled on standard bodies 20-C3 series; for dimensions see catalogue 16.010