

Technical features

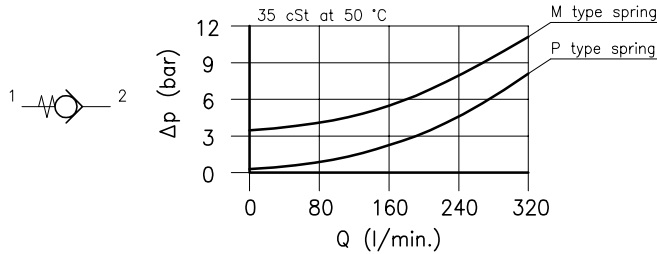

Cavity	(For dimensions see catalogue 17.000)	S 70/2
Nominal flow	(l/min.)	300
Max. pressure	(bar)	420
Cracking pressure	(bar)	0.35-3.5
Fluid viscosity range	(cSt)	2.8 - 380
Fluid temperature range	(°C)	-20 +80
Mass	(kg)	0.480
Hydraulic fluid; mineral oil HM and HV		ISO 6074
Recommended filtration; 19/15 ISO 4466 (25 μ absolutes)		
Standard seals in Polyurethane and Buna N		

Dimensions

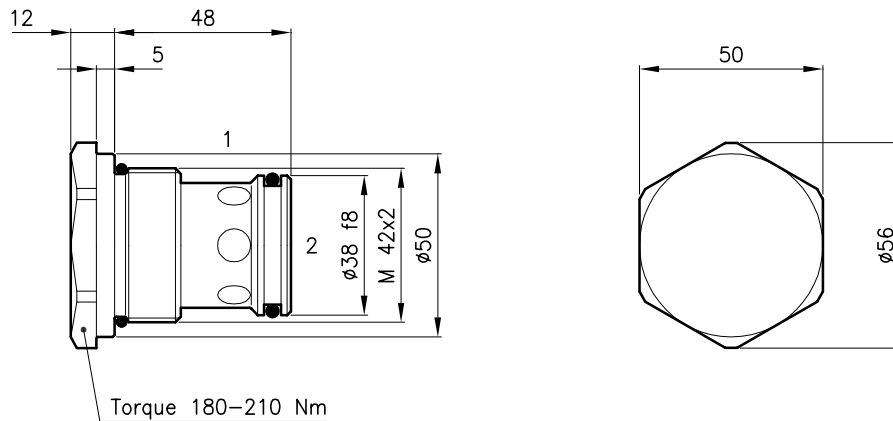

Ordering informations

CAE 70/P

CAE 70 = Valve type

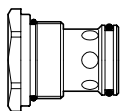

Standard springs

P = 0.35 bar

M = 3.5 bar

Codes:

CAE 70/P 72 011 100

CAE 70/M 72 011 101

External seals kit 90 620 109

CAE 70 valves can be assembled on standard bodies 70-LO series; for dimensions see catalogue 16.010