

**Technical features**

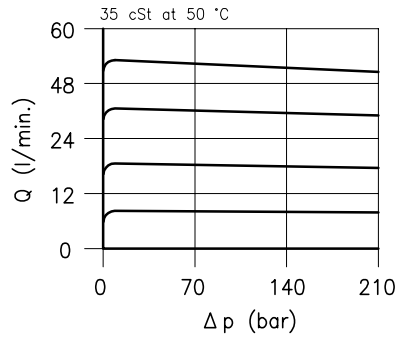

Cavity (For dimensions see catalogue 17.000)	S 50/2	
Flow setting range ± 10% (l/min.)	type U	4 – 8
	type D	8 – 16
	type T	16 – 30
	type Q	30 – 60
Max. pressure (bar)	315	
Fluid viscosity range (cSt)	2.8 – 380	
Fluid temperature range (°C)	-20 +80	
Mass (Standard adjustment type N) (kg)	0.510	
Hydraulic fluid; mineral oil HM and HV	ISO 6074	
Recommended filtration; 19/15 ISO 4466 (25 μ absolutes)		
Standard seals in Polyurethane and Buna N		

**Dimensions**

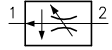
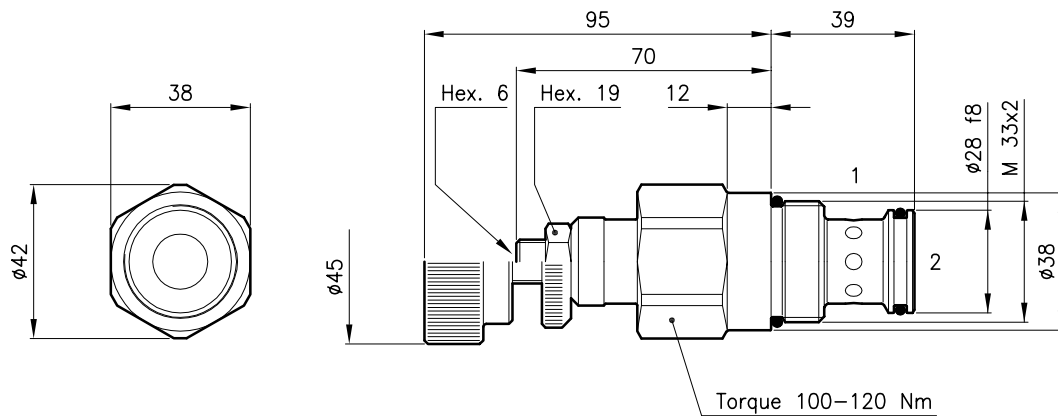

**Ordering informations**

**RDC 50** = Valve type

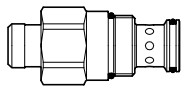

Flow setting range

**U** = 4 – 8 l/min

**D** = 8 – 16 l/min

**T** = 16 – 30 l/min

**Q** = 30 – 60 l/min

Adjustment type

**N** = Standard adjustment

**V** = Handknob adjustment

**RDC 50/D-N**

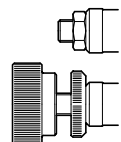

Codes:

RDC 50/U-N 53 011 104

RDC 50/D-N 53 011 105

RDC 50/T-N 53 011 106

RDC 50/Q-N 53 011 107

RDC 50/U-V 53 011 112

RDC 50/D-V 53 011 113

RDC 50/T-V 53 011 114

RDC 50/Q-V 53 011 115

External seals kit 90 620 106

RDC 50 valves can be assembled on standard bodies 50-LO series; for dimensions see catalogue 16.010